

**DELUXE HEATED
DISPLAY CABINET
H-SF SERIES**

**DELUXE COLD
DISPLAY CABINET
SF SERIES**



Temperature Class
+30°C to +85°C

Temperature Class
3M2
+2°C to +8°C

HOT OR COLD

Fan-Forced Element Heating
Consistent heat distribution to hold serving temperature across every level.

Fan Forced Cooling
Uniform frost-free performance, keeps the cake perfectly textured and tasty.

Warm Yellow Lighting
Creates an inviting, "fresh-from-the-oven" look for hot snacks and baked goods.

Cold White LED Shelf Lighting
Crisp, bright lighting on every level to make cakes and drinks stand out.

Purpose-Built Hot Holding
Optimised to maintain stable warmth without relying on refrigeration components.

Natural Eco-Friendly Refrigerant
Uses a greener refrigerant choice for efficient, responsible cooling.



**SF820V
H-SF820V**
600x767x1350mm

**SF830V
H-SF840V**
1728x1095x1300mm

SF840V
1200x740x1350mm

SF850V
1500x740x1350mm

SF860V
1800x740x1350mm

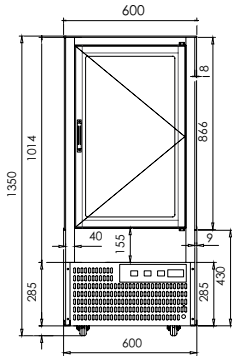

SF820V

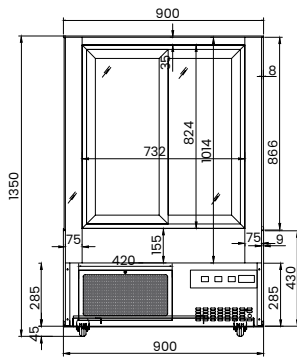

SF830V

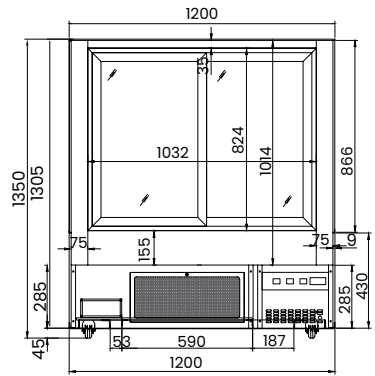

SF840V

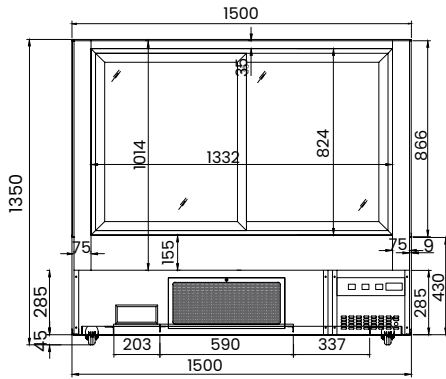

SF850V

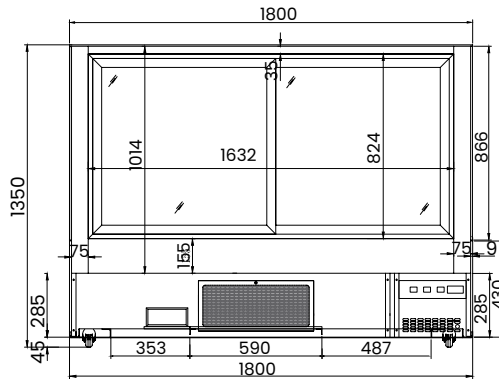

SF860V

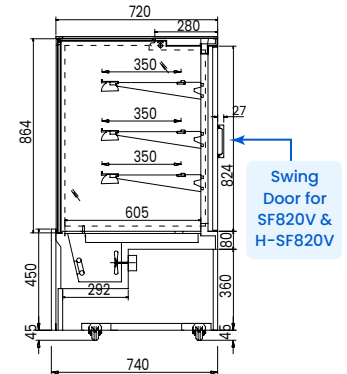

Swing Door for SF820V & H-SF820V

Code	Dimensions (WxDxH mm)	Net Weight(kg)	Net Capacity(L)	Temp Range (°C)	Ambient temp/RH%	Power (W/A)	Display area (m ²)	GEMS Star Rating
SF820V	600x767x1350	128	370	+2 to +8	32°C60%	660/10	-	4
SF830V	900x740x1350	166	560	+2 to +8	32°C60%	845/10	2.23	4
SF840V	1200x740x1350	190	740	+2 to +8	32°C60%	1146/10	2.9	4
SF850V	1500x740x1350	236	930	+2 to +8	32°C60%	1380/10	3.46	4
SF860V	1800x740x1350	256	1120	+2 to +8	32°C60%	1422/10	3.9	4

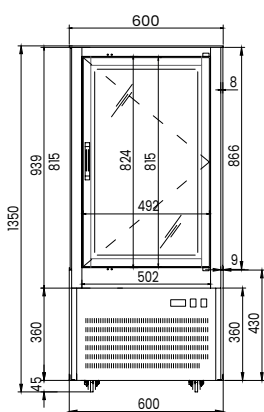

H-SF820V

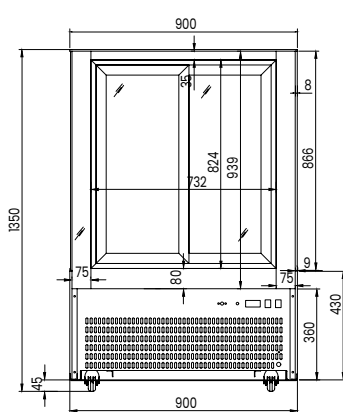

H-SF830V

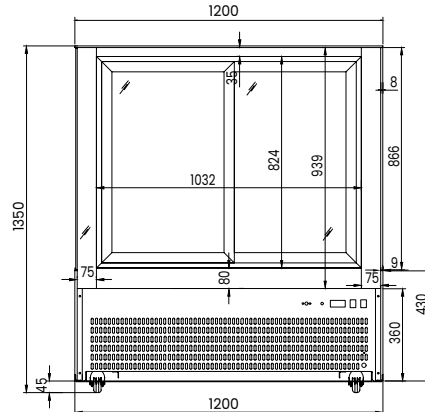

H-SF840V

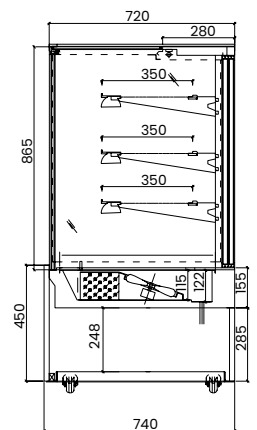

Code	Dimensions (WxDxH mm)	Net Capacity(L)	Weight (kg)	Temp Range (°C)	Voltage	Power (W/A)
H-SF820V	600x767x1350	370	140	+30 to +85	240	786/10
H-SF830V	900x740x1350	560	170	+30 to +85	240	1044/10
H-SF840V	1200x740x1350	740	200	+30 to +85	240	1314/10