

Commercial Crescent Ice Maker

Installation, Use and Maintenance Instructions



12.1.0053-01 A

Table of Contents

Important Information	1
Warning and Safety Instructions	2
General	3
Installation	3
Location for Installation	3
Schematic Diagram of Installation	4
Installation Steps	8
Startup and Operation	8
Operating Instructions	9
Instruction of Control Panel	10
Maintenance	12
Service Call	13
Common Faults and Troubleshooting	13
Warranty	14

 Note: Keep this manual available at any time.

Important Information

Please pay attention to the following warning labels on the ice maker



The label indicates a hazardous voltage. There is a risk of electric shock.

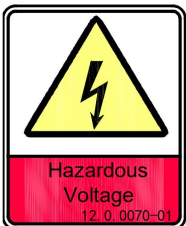

The label indicates a hazardous voltage. There is a risk of electric shock.

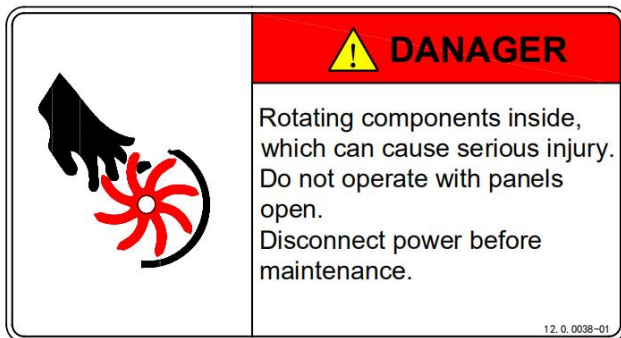

The label indicates rotating components inside. There is a risk of serious mechanical

Instruction of symbols in this Manual

 Alert sign: indicating the item requiring particular attention.

injury.

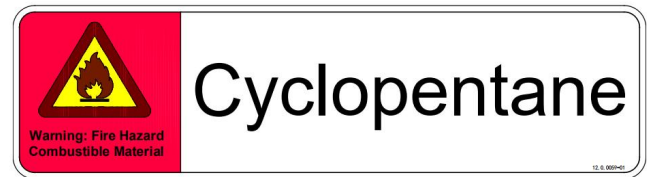

The label indicates a flammable foaming agent “Cyclopentane” used. There is a risk of fire.



R290

The label indicates a flammable refrigerant “R290” used. There is a risk of fire.

 **Warning:** The ice making water inlet of ice maker can only be connected with drinking water, and groundwater or other non drinking water sources can not be used.

Warning and Safety Instructions

 **This product cannot be used in outdoor environment.**

 **This ice machine is not intended for use by children, and those with physical weakness, slow response, or mental disorders.**

- ✦ The installation, repair or maintenance of this ice machine must be carried out by professional and qualified personnel, or electric shock, fire, personal injury may cause from incorrect operation.
- ✦ After the ice machine is delivered, please keep the machine still upright for more than 24 hours, to have the lubricant be fully precipitated before startup, otherwise the compressor may be damaged.
- ✦ When the power cord of the ice maker is damaged, in order to avoid electric shock, fire or personal injury, it must be replaced by the manufacturer or professional and qualified personnel.
- ✦ The water pipe assembly in the accessory box of the ice maker must be used. In order to ensure food safety, the water pipe assembly removed from the old machine should not be used.
- ✦ When handling, keep the cabinet upright, with the inclination not exceeding 45 degrees. Do not invert the machine or lay it horizontally.
- ✦ This ice machine should not be placed in wet or easily splashed area.
- ✦ The grounding of this ice machine cannot be connected to gas pipe, water pipe, telephone line or lightning rods, etc.
- ✦ There are rotating components in this ice machine. Do not insert slim objects into ventilation or exhaust ports, or serious mechanical injury may occur.

- ✦ Do not store volatile or flammable substances in this ice machine, or it may result in explosion or fire.
- ✦ Do not store any **sundries**, or freeze any food in the storage bin. Keep the ice scoop clean.
- ✦ The ice machine must be placed on the floor sufficient to supports its weight. Insufficient base may cause the equipment fall over and cause injury.
- ✦ There should be sufficient ventilation space around the ice machine. Keep good ventilation.
- ✦ Only the power supply specified on the machine nameplate can be used with this ice machine.
- ✦ This ice machine cannot be connected to hot water.
- ✦ Socket for this ice maker must be reliably grounded and with leakage protection.
- ✦ The ice machine must be disconnected from power before manual cleaning, repairing and maintenance.
- ✦ Before cleaning, repairing and maintenance, the remaining ice in the ice bin should be removed from the ice machine to avoid contamination to ice.
- ✦ Do not splash water directly onto the surface of the ice machine during the cleaning process; otherwise it may cause short circuit, leakage or other faults.
- ✦ Flammable foaming agent is used during the foaming process. The ice maker should be disposed of and recycled by qualified personnel and institutions.
- ✦ The ice machine should be properly managed to ensure that children will not play with the machine.

When the ice machine malfunctions, turn off the power and contact professional personnel for repairing.



R290

For the ice maker with flammable refrigerant R290:

- DANGER – RISK OF FIRE OR EXPLOSION. FLAMMABLE REFRIGERANT USED. MUST BE ENOUGH VENTILATION SPACE AROUND THE ICE MAKER TO KEEP THE VENTILATION SMOOTH.
- DANGER – RISK OF FIRE OR EXPLOSION. FLAMMABLE REFRIGERANT USED. DO NOT USE MECHANICAL DEVICES TO DEFROST REFRIGERATOR. DO NOT PUNCTURE REFRIGERANT TUBING.
- DANGER – RISK OF FIRE OR EXPLOSION. FLAMMABLE REFRIGERANT USED. TO BE REPAIRED ONLY BY TRAINED SERVICE PERSONNEL. DO NOT PUNCTURE REFRIGERANT TUBING.
- DANGER – RISK OF FIRE OR

EXPLOSION. FLAMMABLE REFRIGERANT USED. DO NOT USE ANY ELECTRICAL APPLIANCES IN THE ICE STORAGE BIN OF THE ICE MAKER.

- CAUTION – RISK OF FIRE OR EXPLOSION. FLAMMABLE REFRIGERANT USED. CONSULT REPAIR MANUAL/OWNER'S GUIDE BEFORE ATTEMPTING TO SERVICE THIS PRODUCT. ALL SAFETY PRECAUTIONS MUST BE FOLLOWED.
- CAUTION – RISK OF FIRE OR EXPLOSION. DISPOSE OF PROPERLY IN ACCORDANCE WITH FEDERAL OR LOCAL REGULATIONS. FLAMMABLE REFRIGERANT USED.
- CAUTION – RISK OF FIRE OR EXPLOSION DUE TO PUNCTURE OF REFRIGERANT TUBING; FOLLOW HANDLING INSTRUCTIONS CAREFULLY. FLAMMABLE REFRIGERANT USED.

General

The ice machine is fully automatic. With proper installation and connection to potable water and power source, the ice making will start properly. When the ice cubes fill up the storage bin, the machine will automatically stop. The ice machine is generally used in the following and similar occasions:

- The kitchen area of a store, office or other workplace;
- Farm, hotel, car hotel and restaurant;
- Catering and similar non-retail occasions;
- This ice machine is not intended for used at home.

Installation

Location for Installation

The ice machine should be installed in a proper location meeting the following conditions:

- Indoor, not more than 2,000 meters above sea level;
- Ambient temperature: 5-40°C;
- Power supply: the rated voltage indicated on the machine nameplate $\pm 6\%$;
- Water source: potable water, with water pressure from 0.13MPa to 0.55MPa; water temperature: 5-35°C;
- The ice machine should be kept away from heat sources, and should be strictly forbidden to use at extremely high

temperature or low temperature environment, and should avoid direct sunlight.

- There should be sufficient ventilation space around the ice machine and keep good ventilation;
- The ice machine must be placed on a floor sufficient to support its weight;
- Socket for the ice maker must be reliably grounded and with leakage protection;
- Proper floor drainage must be provided near the installation location of the ice machine.

Schematic Diagram of Installation

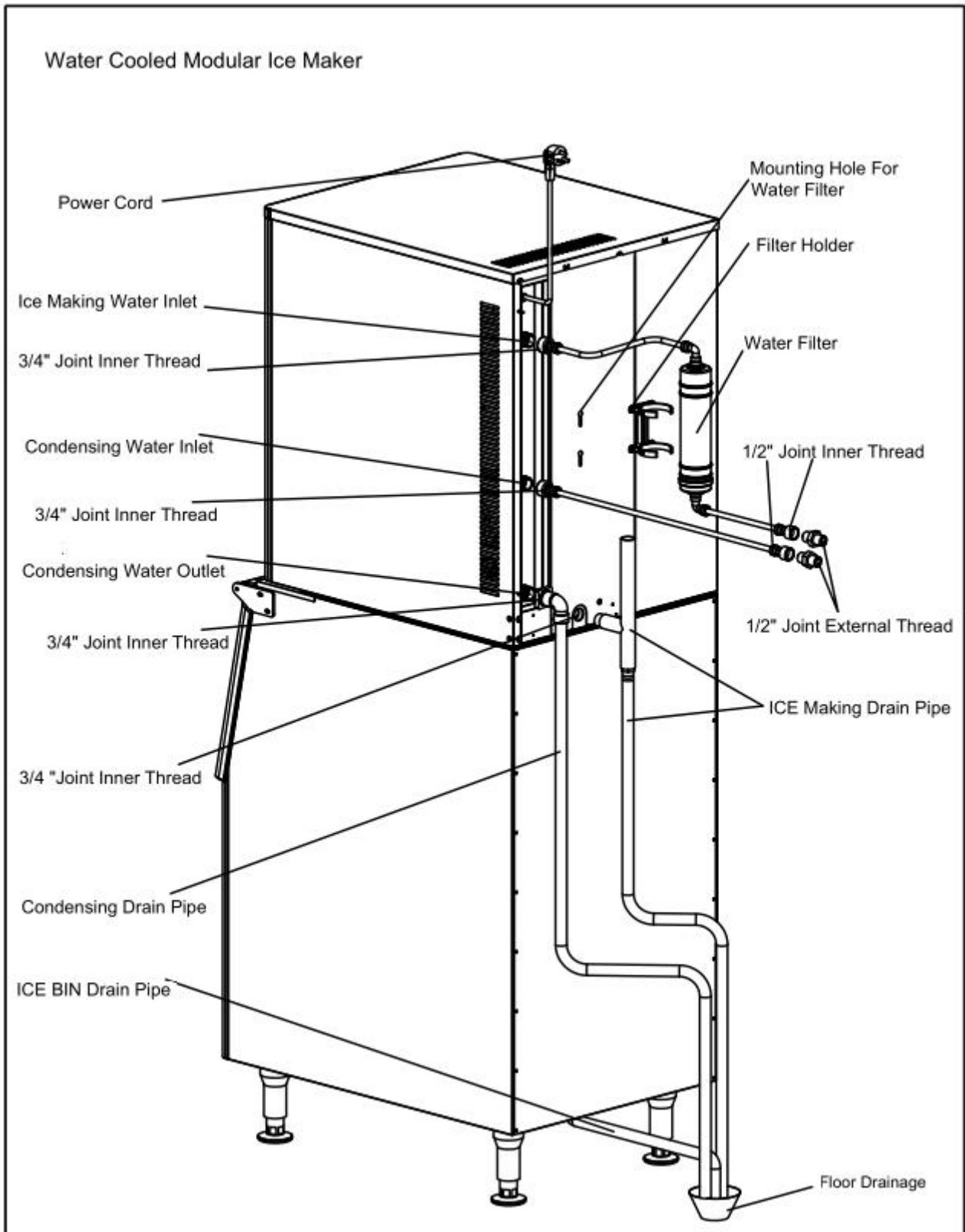

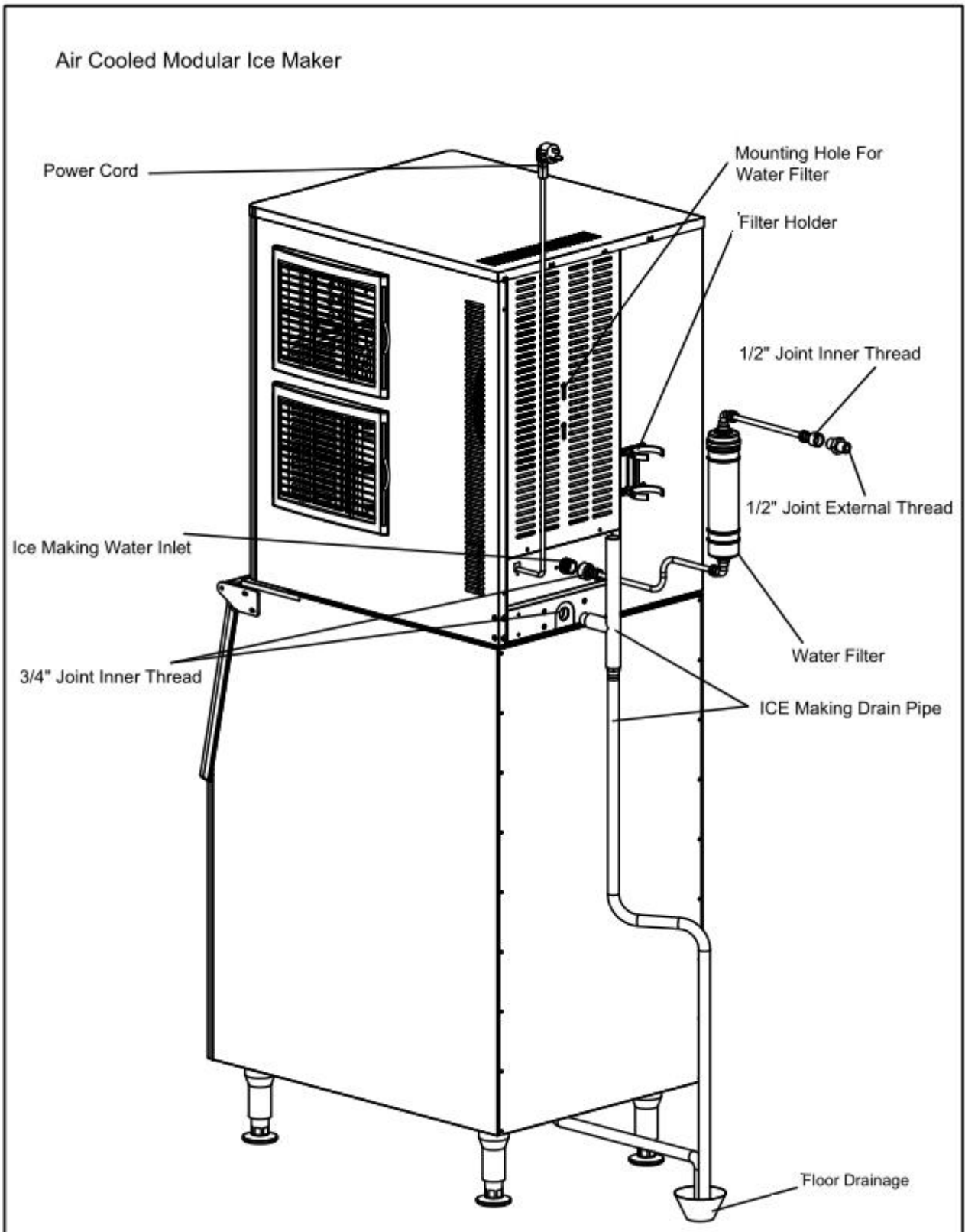

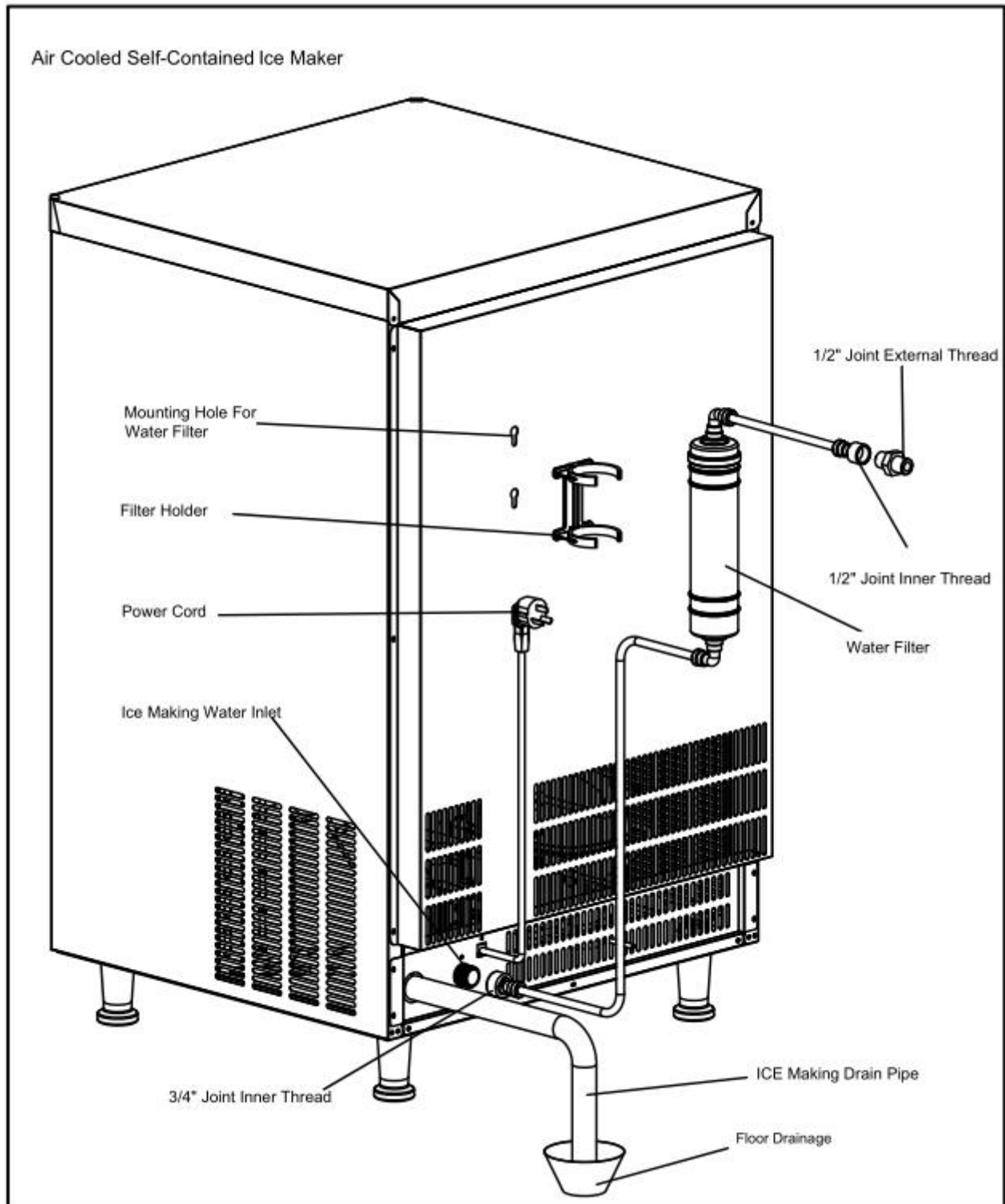

Air Cooled Undercounter Ice Maker

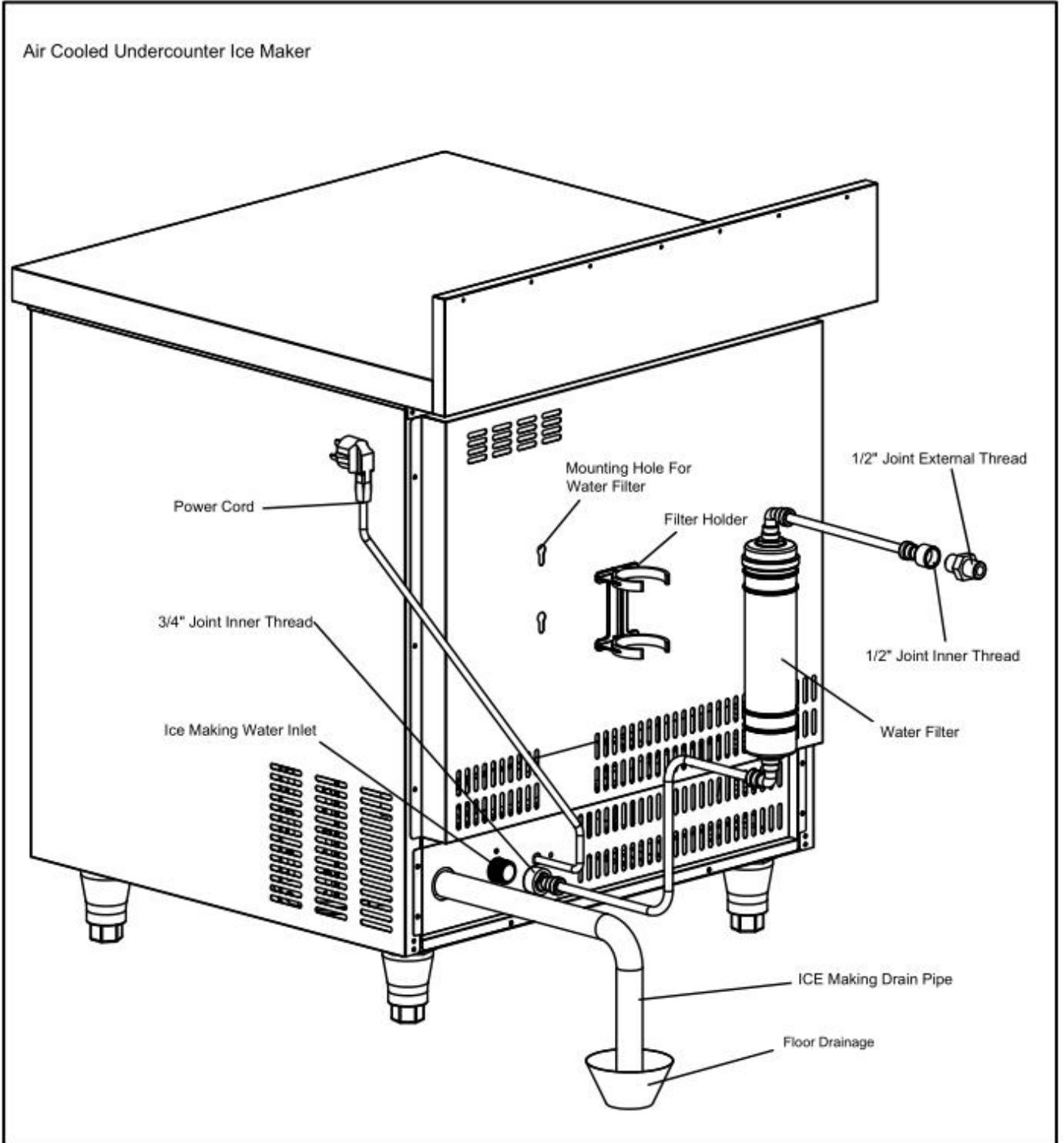

Installation Steps

1. Check whether the ice maker is in good conditions and whether accessories are complete. Check its model and nameplate.
2. For the self-contained crescent ice maker, it is necessary to open the door and remove the tapes of the full ice sensor and water baffle. They are used to prevent possible damage during transportation.
3. Clean the ice bin and inside with a sponge that has been soaked in warm water and baking soda. Then rinse them with clean water and dry them.
4. Set up the ice maker in the operation area. Keep it horizontal to ensure that the water through the water separator flows evenly on the evaporator and in the ice tray.
5. The nacelle is at the lower part of the front of the self-contained crescent ice maker and on the right of the head of the modular crescent ice maker. The compressor and condenser of the refrigeration system are mounted inside the nacelle. The air-cooled ice maker should be installed in a well-ventilated place. Therefore, a ventilation space of 20-30cm or more must be kept in front of and behind the ice maker.
6. There are adjustable legs at the bottom of the ice maker, to facilitate level adjustment and floor cleaning.
7. Connect the water inlet filter and water pipe of the ice maker as shown in the figures. If there is a drinking water system on the installation site, it is not necessary to install a water filter.

⚠ Note: There are water inlet and outlet marks on the filter cover or bottle. Please

install the filter in the correct direction.

⚠ Note: The ice maker is supplied with a water inlet filter. Impurities from water are accumulated in the filter during operation. Therefore, the filter needs to be replaced once every 1 to 3 months under normal circumstances.

8. Connect the ice maker with a water supply pipe via the accompanying 3/4" water inlet pipe. A water valve (not supplied along with the ice maker) is recommended on the water supply pipe.
9. Connect the accompanying drain pipe to the drain port (the drain pipes of the modular crescent ice maker consist of the drain pipe and drain hose, which should be installed as indicated in the figures). To facilitate drainage, the recommended drop per meter of drain pipe is greater than 3m. Make sure that the drain pipe is not blocked. It is recommended to discharge water from the drain pipe to open drain port.
10. Any node in the drain pipe must not be higher than both the water outlet of the ice maker and the previous node.
11. Confirm the power supply requirements in the nameplate, and use the conforming power supply.
12. Set up a circuit breaker switch on the power cord. In addition, use a leakage protector, which should be grounded reliably.
13. Turn off the switch on the power cord before connecting the machine to a power supply.

Startup and Operation

14. Before startup, make sure that:
 - The tapes inside the ice maker are removed;
 - The accessories or items inside the ice maker are taken out;
 - The ice maker is adjusted to a horizontal state;
 - The water pipe is connected and the water valve is open;
 - The plug is connected to the power

supply, and the power switch is off;

- Make sure that the ambient temperature, water temperature and water supply pressure are within the aforesaid ranges.
15. Startup: Turn on the power switch of the power cord. When powered on, the machine will be in the state of automatic ice making.
 16. During normal operation:

- ✓ Make sure that there is water in the water tank, without spillage;
- ✓ Make sure that the water pump is working normally and that water flows down evenly from the ice tray;
- ✓ Make sure that the compressor is working normally and that the temperature of the ice tray and ice making water decreases gradually;
- ✓ Make sure that the fan is working normally and that there is stable air flow at the inlet and outlet of the ice maker;
- ✓ Make sure that the ice maker is free of abnormal noise;
- ✓ Make sure that the ice maker is free of abnormal vibration;
- ✓ It takes about 25-40 minutes to make an ice cube, depending on the ambient temperature and water temperature. The higher the ambient temperature and water temperature, the longer the ice making time.
- ✓ Make sure that ice can be separated normally.

Operating Instructions

- **Startup:** Install the ice maker correctly, and turn on the water source and power supply. The machine will be in the normal working state. It works automatically in the whole process. Make sure that it works normally after turning it on for the first time.

⚠ Note: Cut off the power supply and water source in case of thunderstorm or if the ice make is not in use in a long time.

- **Preparation:** When the ice maker is powered on, the water inlet valve will be opened automatically, and water will be supplied to the set level.
- **Ice making:** The water pump is started 20 seconds after pre-cooling. Water flows continuously and smoothly through the evaporator, and crescent ice cubes are gradually made in the ice grids of the evaporator.
- **Ice falling:** When the specified ice making time is up, the water pump will be turned off, and the water inlet valve and defrost valve will be energized and

opened. Ice cubes will fall from the evaporator into the refrigerator in about 3-6 minutes.

⊘ Warning: Do not put your hands into the ice bin when ice cubes are falling down, in order to prevent the hands from injuries caused by falling ice cubes!

- **Shutdown:** Click “ON/OFF” on the panel. The ice make will immediately stop running.
- **Automatic stop with full ice:** When the ice maker is running, and ice cubes in the ice bin are accumulated to a certain height, affecting the falling of the ice cubes that are newly made, and the ice chute cannot be reset, the machine will detect that the ice bin is full of ice cubes in some time (approximately 40 seconds) and automatically stop working.
- **Restart of ice making:** When ice cubes in the ice bin are removed and the machine detect that the ice chute is reset, it will restart normal ice making in 90 seconds.

Instruction of Control Panel

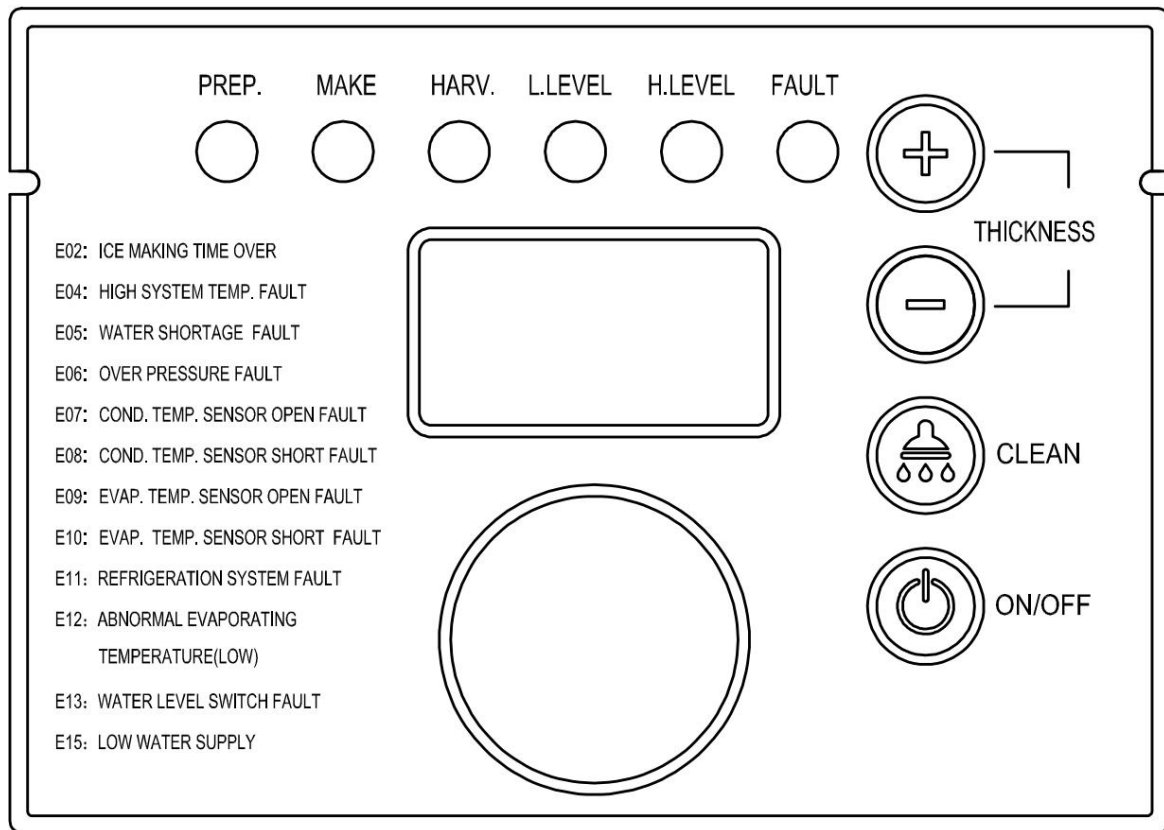

cleaning must not be discarded.

1. Digital tube: display different contents at each stage:
 - a) Preparation period: 360-second countdown.
 - b) Ice making period: positive counting in second.
 - c) Ice falling period: positive counting in second.
 - d) Cleaning period: display the code of the cleaning process: "CLE" for cleaning with detergent/disinfectant and "rin" for rinsing.
 2. LED indicator: display the status of the ice maker, i.e. preparation, ice making, ice falling, low level, high level, and fault.
 3. Cleaning: Click "Clean" during normal operation to enable the cleaning cycle. The user needs to fill detergent and disinfectant in the cleaning process. After automatic cleaning is completed, the ice maker will automatically restart ice making.
 4. ON/OFF: When the ice maker is powered on, click "ON/OFF" to shut it down or run it.
 5. Voice (only for the machine with cleaning function): For the machine with a voice broadcast function, relevant operations are accompanied by voice prompts.
 6. Open and close the door of the ice bin gently. Do not slam the door. After taking out ice cubes, close the door of the ice bin.
 7. If not in use for a long time, the ice maker should be powered on and run for 2 to 4 hours every 2 months.
- Other Special Protection by Shutdown**
- When the ice maker detects that the ambient temperature is too high, it will shut down for protection.
 - When the water-cooled ice maker detects a water pipe abnormality, it will shut down for protection.

⚠ Note: The first five ice cubes made

- When a fault occurs, the fault code and explanation will be displayed as follows:

Code	Explanation	Action		
E02	Ice making timeout fault	Shutdown for protection	E08	Short circuit fault of condensing sensor Without shutdown
E03	Ice falling fault	Shutdown for protection	E09	Open circuit fault of evaporation sensor Without shutdown
E04	High temperature fault (pressure over-limit in voice broadcast)	Shutdown for protection	E10	Short circuit fault of evaporation sensor Without shutdown
E05	Water shortage fault	Shutdown for protection	E11	Refrigeration system fault Without shutdown
E06	High pressure fault	Shutdown for protection	E12	Water pump or pipe fault Shutdown for protection
E07	Open circuit fault of condensing sensor	Without shutdown	E13	Level switch fault Shutdown for protection
			E15	Low flow rate of water Without shutdown

Maintenance

 **Note:** Maintenance must be completed by qualified professionals.

 **Warning:** Before maintenance and manual cleaning, cut off the water source and power supply, and remove the plug. It is forbidden to carry out maintenance and manual cleaning in the live state.

External cleaning

- Always clean the area around the ice maker to keep it clean. Do not block the vent.
- Clean the shell with neutral detergent and wipe it with soft cloth. If necessary, use commercial stainless steel cleaner and polishing agent.

 **Note:** Stainless steel may rust without proper maintenance.

Water inlet filter

- Check the filter element regularly. It is recommended to replace the filter element at intervals of 1-3 months.

Internal cleaning

- Directly rinse the ice bin via the water pipe.

 **Note:** The water pressure must not be too high. Do not directly rinse the part above the water pump and ice grids, in order to prevent circuits from drenching in water.

Water pipe

- Clean the water pipe of the ice maker regularly to ensure food hygiene.

Overwinter

- Turn off the water source and power supply, and discharge the remaining water in the water tank, water inlet pipe and drain pipe of the ice maker.

 **Maintenance of the ice maker is not covered in the manufacturer's warranty!**

Automatic cleaning of ice maker

 **Note:** Before automatic cleaning and disinfection, take ice cubes out of the ice bin to avoid contamination.

 **Note:** Clean and disinfect the ice bin manually and rinse it.

 **Note:** In order to fully clean and disinfect the ice maker, dismantle and separately clean and disinfect the water tank, water pump, spray pipe and water inlet pipe. In addition, dismantle and separately clean and disinfect the ice tray and drinking water splashing area,

and rinse them.

- Turn on the ice maker, and make sure that ice cubes have been taken out of the ice bin. Press and hold “Clean” for 3 seconds. After water is filled, the ice maker will be in the waiting state. Discharge water inside the water tank.
- Transfer the prepared cleaning (or disinfecting) solution equivalent to the capacity of the water tank into the water tank. Press “Clean” to automatically enable the cleaning mode. Cleaning will be performed cyclically for 15 minutes (the digital tube displays “CLE”).
- After automatic cleaning is completed, the ice maker will be in the rinsing mode. Rinsing will be performed for 5 cycles and 25 minutes in total (the digital tube displays “rin”). The ice tray can be cleaned (or disinfected) with sprinkling can.
- After cleaning (or disinfection) is completed, the ice maker will be in the standby state (the digital tube displays “OFF”).
- Cleaning and disinfection steps are exactly the same except for the cleaning medium.
- In order to ensure the food hygiene, please discard the first five ice cubes.

Condenser

- For the air-cooled ice maker, the condenser should be cleaned once every three weeks with a soft brush or vacuum cleaner

containing a brush up and down along fins, to avoid fin damage and its impact on the refrigeration effect.

- Clean the filter screen of the condenser once every half a month.
- Removal of the stainless steel filter screen of the front ventilation window: Gently press two buckles on the ventilation window toward the middle, take out the ventilation window, and pull out the filter screen from the side of the ventilation window.

Schematic diagram of filter screen removal of self-contained crescent ice maker:

Schematic diagram of filter screen removal of modular crescent ice maker:

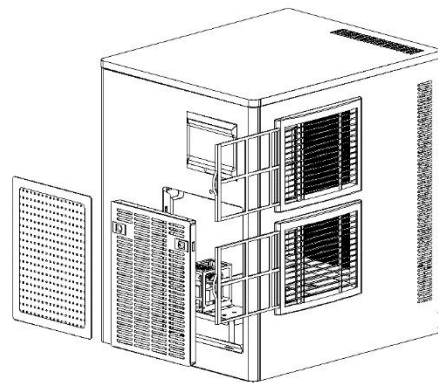
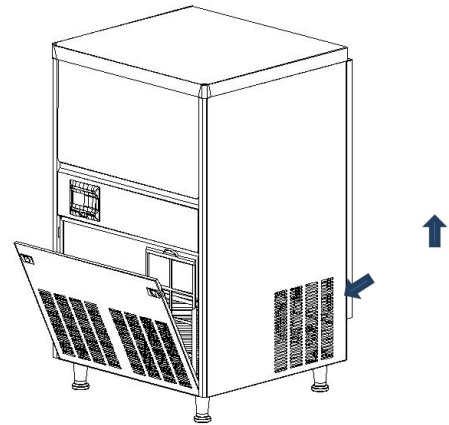

⚠ Note: The edges of the fins of the air-cooled condenser are sharp. Be careful during cleaning!

Service Call

In case of any abnormality of the ice maker, check the following before dialing the service hotline.

1. Make sure that the water source is in the normal state.
 - ✓ Check whether there is water inside the water tank of the ice maker.
 - ✓ Make sure that the water pressure inside the ice maker is 0.13MPa to 0.55MPa; and the water temperature is 5-35°C.
 - ✓ Make sure that the water valve has been opened.
 - ✓ Make sure that there is no water leakage.
2. Check whether the power supply is connected.

- ✓ Make sure that the indicator on the display panel is ON.
 - ✓ Make sure that the panel does not display the standby state "OFF".
 - ✓ If the LED indicator on the panel is OFF, check whether the power plug and socket are in the normal state and whether the switch on the power cord is ON.
3. Check the nameplate and number of the machine.
 - ✓ Check the nameplate on the side or back of the ice maker, and record its model and number.

⚠ Note: If a fault occurs for the user's reasons, such as no water, no power supply, environmental factors and others, on-site services will be charged.

Common Faults and Troubleshooting

Fault and Phenomenon	Possible Cause	Inspection and Troubleshooting
Failure of the ice maker to start running OFF state of the indicator on the panel	The power switch is not turned on. The plug is loose.	Turn on the power switch. Check the plug and socket.
Automatic shutdown 3 minutes after startup, and display of E04 high temperature protection on the display screen Display of E06 high pressure protection on the display screen	The ambient temperature is too high. The condenser is dirty. The harness of the high-voltage switch falls off. The fan is not started normally.	The normal working temperature is 5-40°C. Clean the condenser. Check the harness of the high-voltage switch and take corrective measures. Check the fan and take corrective measures.
Failure in ice falling	The ambient temperature is too low. The defrost valve is not opened normally.	The normal working temperature is 5-40°C. Check the defrost valve and take corrective measures.
Poor transparency of ice cubes, and too thin or incomplete ice cubes Too long ice falling Low flow rate of water	The water pressure is insufficient. The water temperature is too high. The water inlet valve does not work. The water inlet valve is dirty. Water leakage occurs. The water inlet filter is not replaced in a long time.	Check whether the water pressure is 0.13MPa to 0.55MPa. Check whether the water temperature is 5-35°C. Check the water inlet valve and take corrective measures. Check whether water leakage occurs and take corrective

		measures. Check the water inlet filter and take corrective measures.
Slow ice making	The condenser or filter screen is dirty. The ambient temperature is high. Ventilation is poor. The water temperature is too high.	Clean the condenser and filter screen. The normal working temperature is 5-40°C. Check the surrounding environment of the ice maker. Check whether the water temperature is 5-35°C.
Too high noise	The ice maker is not secured, and its feet are suspended.	Keep the ice maker secured.

Warranty

The following occasions are excluded from the warranty of the ice maker:

- Normal cleaning, maintenance, adjustment and maintenance;
- Unauthorized modification of the ice maker or use of non-original parts;
- Damage arising from improper power supply, water supply and drainage;
- Damage caused by noncompliance with the instructions during installation, cleaning or maintenance;
- Damage caused by scale produced in water source;
- Man-made damage.

⚠ Note: Warranty services should be performed by an agent or maintenance organization approved by the company.

Note: this Manual is subject to any technical change without further notice. Please refer to the nameplate on the product for exact information.

