

535L Gelato/ Ice Cream Display

SD-575P

The product features a transparent glass design for a 360° unobstructed display of gelato's vibrant colors and textures. It also includes an internal LOW-E glass design for excellent insulation and energy efficiency. The unit has compartmentalized sections for different ice cream flavors, storage functionality, and a drainage tray. The sliding glass door allows for easy ice cream replacement, while a lock and key provide security. Additionally, the product strictly adheres to food safety certification standards, including IEC/IECEE certification and an 8-star GEMS rating.



Key Features



GEMS Compliant

Greenhouse and energy minimum standards



Static Cooling

Keeps ice cream perfectly textured and tasty.



360° Unobstructed Display

Showcase the vibrant colors and texture of Gelato.



LOW-E Glass Design

High-efficiency insulation energy-saving anti-fog/condensation.

Details

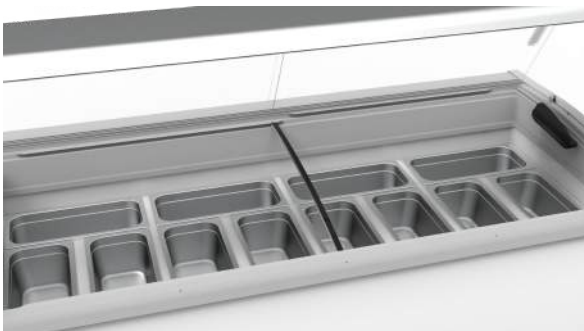

- With a total capacity of 60L for 12 pans, it meets various varieties and flavors of gelato.
- A wide range of containers is available, such as portion tubs, cylinders, and cakes.

Code	GEMS Star Rating	Dimensions (W x D x H mm)	Weight (kg)	Temperature Class	Max. ambient temp/RH%	Power (W/A)
SD-575P	8	1720x838x1270	152	-12°C to -15°C	30°C/55%	420/10



Brilliant LED Lighting

Showcases items with several individually lights.



Sliding Glass Door

Optimised slide rail design for reduced resistance Smooth movement.



The Gelato Pans

Total 60L capacity with 12 gelato pans for various flavors.



Fog-Proof Condensation-Proof

Maintenance-free, preserving the premium quality of ice cream.



Leak Prevention Function

Keeps the display cabinet dry.

Product Design Overview

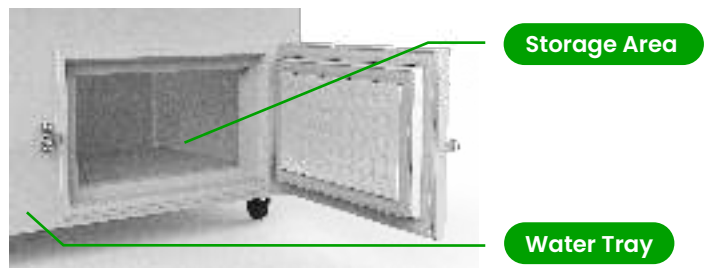
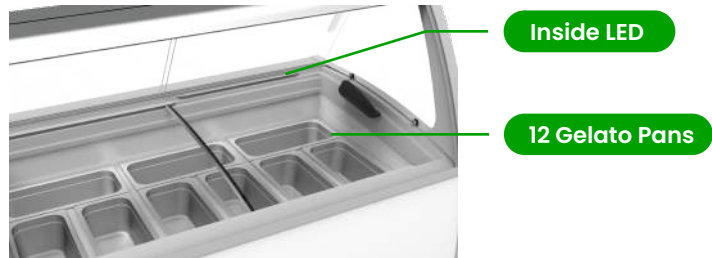
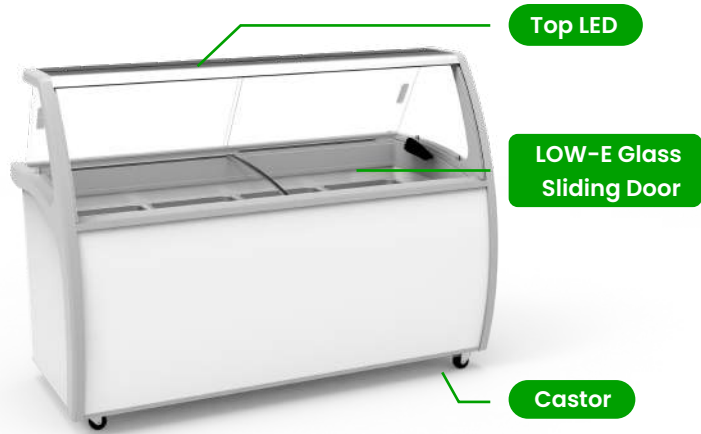

Product Summary



The product features a transparent glass design for a 360° view of gelato's colors and textures, LOW-E glass for insulation and energy efficiency, compartments for different ice cream flavors, storage space, a drainage tray, and a sliding glass door for easy ice cream replacement. It includes a lock and key for security and meets food safety standards, including IEC/IECEE certification and an 8-star gems rating.

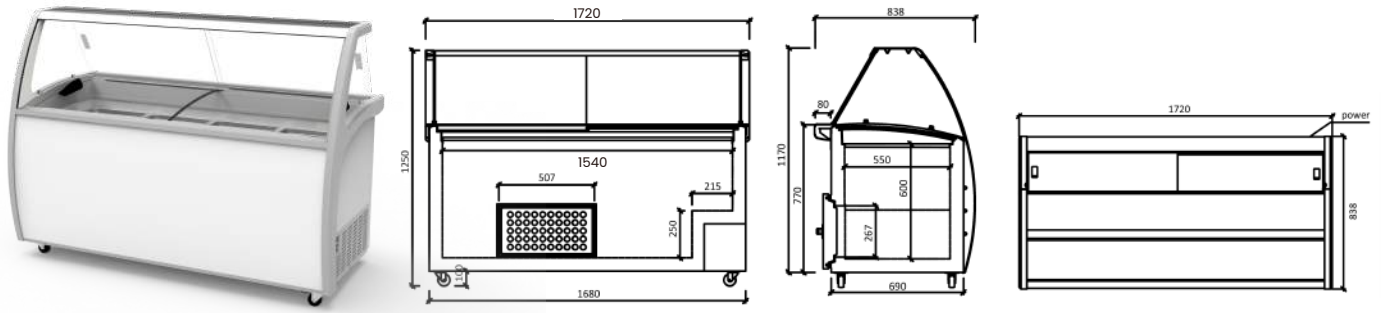

FEATURES AND FUNCTIONALITIES	
Cooling System	Static Cooling
Compressor Unit	Cubigel
Energy Efficiency	5.226 kWh/24h
Exterior & Interior of the Cabinet	Exterior Body White, Interior Body White, Pre-painted Steel.
Ergonomical Design	LED lights; Water tray 0.45L; 4 casters for easy movement; Compartmentalised design; Lock and key; Washing ank.
Durable Door Profile	LOW-E and tempering Glass sliding door.
Gelato Pan	12 Pans, 5L/pan; 304SS.
Blowing Agent	70mm, Cyclopentane.

TECHNICAL DESCRIPTION	
Power Cord	10Amp plug and lead
Power cord length	2.9m (2.2m outside cabinet)
Power Supply	240V/50Hz; 420W
Rated Current	2.2A
Evaporator Design	Galvanized Steel Tube
Compressor cooling capacity(W)	514
LED Lights	1x12.5W LED strip, upper inner liner 1x17W LED strip, underneath top plate 3x14.5W LED strips, front panel

SAFETY & STANDARDS	
IEC/IECEE CB; GEMS(Refrigerated Cabinets) Determination 2024 ; EN 16838:2016;	

PHYSICAL QUALITIES	
Width (mm)	1720
Depth (mm)	838
Height (mm)	1270
Packing Width (mm)	1850
Packing Depth (mm)	1005
Packing Height (mm)	1310
Net Weight (kg)	152
Total Capacity (L)	535
Total Display Area [m ²]	0.71

PERFORMANCE SPECIFICATION	
Max. ambient temp/RH	30°C 55%
Climate Class	4
Temperature Class	-12°C to -15°C
Rated kWh/year	1907.49
Refrigerant	R290 (130g)
Energy Efficiency Index (EEI)	16
Star Rating / GEMS Rating	8 (4L3)

WARRANTY	
1 Year Parts and Labour	



Customisation Options

Customised corporate solutions available upon request



Suitable For Various Scenarios



Ice Cream Shops



Outdoor Shops



Restaurants



Cafes



Supermarkets



Convenience Stores