



# Undercounter Solid Door Fridges & Freezers, Glass Door Fridge



## XUB 6 S/XUB 7 S/ XUB 7 G SERIES

XUB6C13S2V/XUB6C18S3V/XUB6C22S4V/XUB6F13S2V/XUB6F18S3V,  
XUB7C13S2V/XUB7C18S3V/XUB7C22S4V/XUB7F13S2V/XUB7F18S3V,  
XUB6C13G2V/XUB6C18G3V/XUB7C13G2V/XUB7C18G3V/XUB7C22G4V

### KEY FEATURES



#### Reliable Cooling Performance

Fan-forced evaporator cooling ensures consistent temperatures and rapid recovery in demanding kitchens.



#### Adaptable Configurations

Available in solid door, glass door, or drawers, with optional depths (600mm and 700mm) to suit every workspace.



#### High-Performance Stainless Steel Cabinet

60mm thick polyurethane foam to ensure stable temperature performance even in high ambient conditions.



#### Energy Efficient Design

R290 refrigerant lowers energy use and environmental impact, paired with high-density, HFCs and CFCs free insulation for maximum cooling efficiency and minimal energy loss.

### DETAILS

The Fed-X XUB 600 & 700 Series undercounter fridges and freezers combine form, function, and reliability for professional kitchens. Built from high-grade stainless steel, each model delivers robust cooling and easy maintenance in a compact footprint. These units are engineered to fit seamlessly beneath prep benches or serve as standalone worktops, making them a versatile solution for cafés, restaurants, and catering operations.

Available in solid door or glass door configurations with optional 600mm or 700mm depths, the XUB Series provides flexible choices for any workspace. Each unit features fan-forced evaporator cooling for even air distribution, digital temperature controls for accuracy, and heavy-duty castors for effortless mobility. LED-lit glass door models provide full product visibility, while solid door variants maximise energy efficiency and cold retention.



**ENERGY RATING**  
THE MORE STARS  
THE MORE SAVINGS



AUS Phone: 1300 659 409  
Email: [sales@foodequipment.com.au](mailto:sales@foodequipment.com.au)  
[www.foodequipment.com.au](http://www.foodequipment.com.au)



NZ Phone: 09 415 6470  
Email: [sales@fedproducts.co.nz](mailto:sales@fedproducts.co.nz)  
[www.fedproducts.co.nz](http://www.fedproducts.co.nz)

# XUB 6 S/XUB 7 S/ XUB 7 G SERIES



## Premium Condenser Fans

Efficient evaporator and condenser fans enhance cooling performance.



## Self-Closing Magnetic Doors

Maintain consistent temperature and improve convenience.



## Auto Defrost Function

Reduces manual maintenance and downtime.



## Tropicalised Design

Engineered for reliable operation in high ambient temperatures.



## Adjustable Shelving

Each door compatible with removable GNI/1 shelf for easy organisation.



## Heavy-Duty Castors

Front wheel brakes ensure safe, stable placement.

## SOLID DOOR MODELS

Stainless Steel Construction

Optional drawer combinations available in place of doors.

Fully insulated stainless steel doors for superior cold retention.



Lock & Key

Digital Controller

Integrated Door Handle

Heavy-Duty Magnetic Door Seals

## GLASS DOOR MODELS



Fan Vents

Adjustable Shelf (Holds 40 kg Per Shelf)

Heavy-Duty Castors with Front Wheel Brakes

Self Closing Doors

LED internal lighting for visibility and display appeal.

Double-glazed glass for insulation and reduced condensation.



# XUB 6 S/XUB 7 S/ XUB 7 G SERIES



XUB6C13S2V / XUB6F13S2V

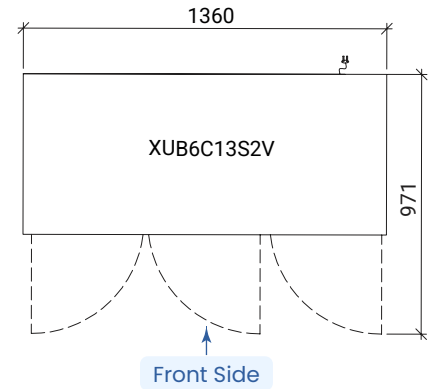
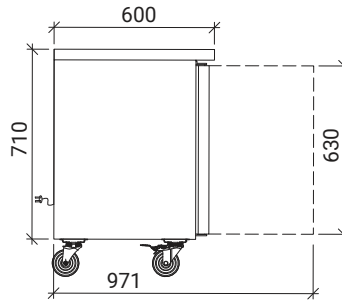
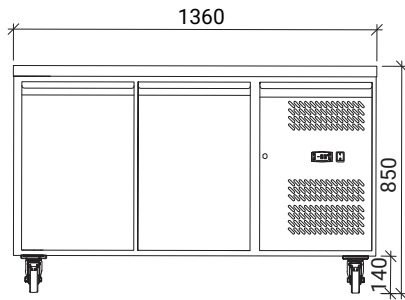

Front Side

XUB6C18S3V / XUB6F18S3V

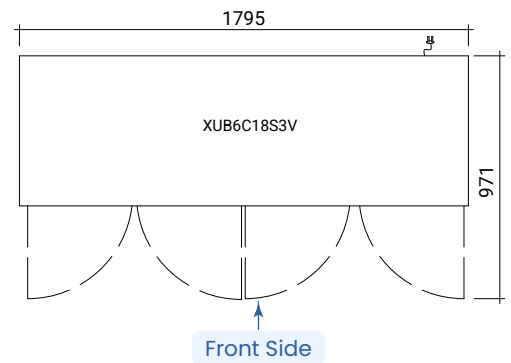
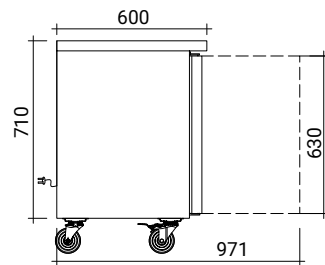
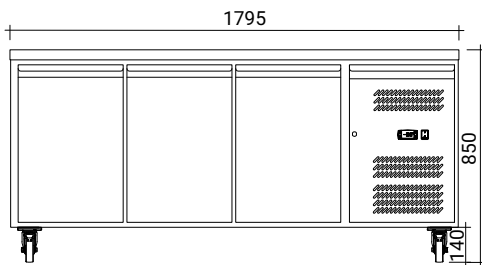

Front Side

XUB6C22S4V

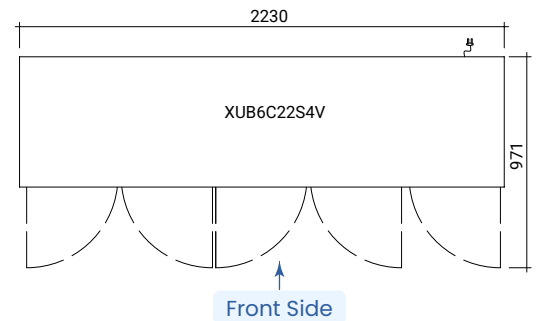
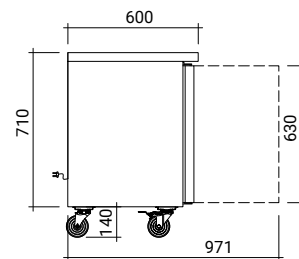
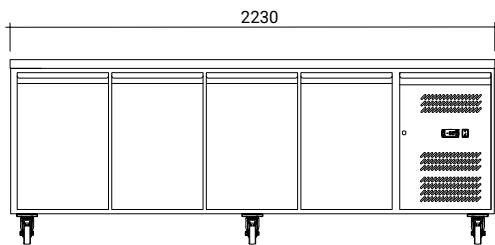

Front Side

Code	GEMS Star Rating	Gross Capacity (L)	Net Capacity (L)	Doors	Dimensions (WxDxH mm)	Weight (kg)	Temp. Range (°C)	Ambient°C/ RH%	Power (W/A)
<b>Workbench Fridges</b>									
XUB6C13S2V	5	228	170	2	1360x600x850	83	-2 to +8	43/60	215/10
XUB6C18S3V	4	339	254	3	1795x600x850	105	-2 to +8	43/60	230/10
XUB6C22S4V	3	449	339	4	2230x600x850	121	-2 to +8	43/60	345/10
<b>Workbench Freezers</b>									
XUB6F13S2V	2	228	170	2	1360x600x850	107	-22 to -18	38/40	520/10
XUB6F18S3V	2	339	254	3	1795x600x850	134	-22 to -18	38/40	560/10

To ensure we continuously offer the best possible products, we reserve the right to modify specifications without any obligation for equipment previously or subsequently sold.



AUS Phone: 1300 659 409  
Email: sales@foodequipment.com.au  
www.foodequipment.com.au



NZ Phone: 09 415 6470  
Email: sales@fedproducts.co.nz  
www.fedproducts.co.nz

# XUB 6 S/XUB 7 S/ XUB 7 G SERIES



XUB7C13S2V / XUB7F13S2V

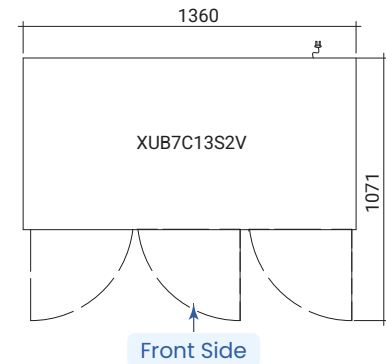
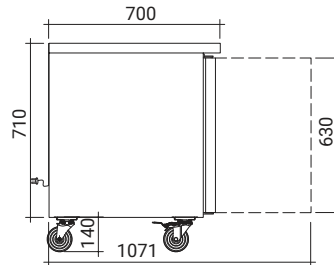
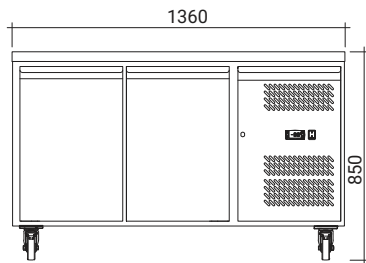

Front Side

XUB7C18S3V / XUB7F18S3V

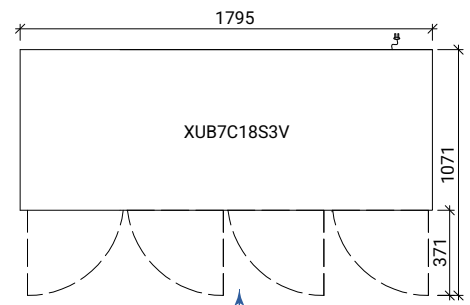
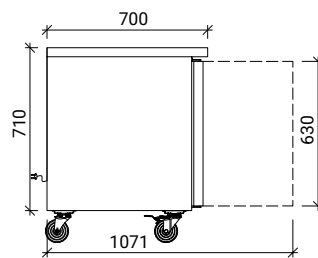
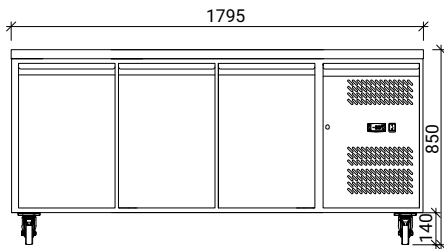

Front Side

XUB7C22S4V

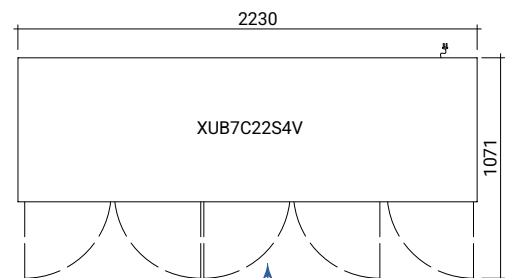
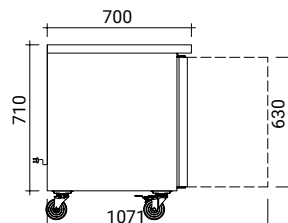
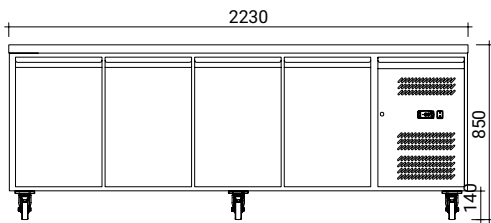

Front Side

Code	GEMS Star Rating	Gross Capacity (L)	Net Capacity (L)	Doors	Dimensions (WxDxH mm)	Weight (kg)	Temp. Range (°C)	Ambient°C/ RH%	Power (W/A)
<b>Workbench Fridges</b>									
XUB7C13S2V	5	282	186	2	1360x700x850	102	-2 to +8	43/40	215/10
XUB7C18S3V	4	417	311	3	1795x700x850	121	-2 to +8	43/40	230/10
XUB7C22S4V	3	553	415	4	2230x700x850	150	-2 to +8	43/40	345/10
<b>Workbench Freezers</b>									
XUB7F13S2V	2	282	186	2	1360x700x850	107	-22 to -18	43/60	520/10
XUB7F18S3V	2	417	311	3	1795x700x850	146	-22 to -18	43/60	560/10

To ensure we continuously offer the best possible products, we reserve the right to modify specifications without any obligation for equipment previously or subsequently sold.



AUS Phone: 1300 659 409  
 Email: sales@foodequipment.com.au  
 www.foodequipment.com.au



NZ Phone: 09 415 6470  
 Email: sales@fedproducts.co.nz  
 www.fedproducts.co.nz

# XUB 6 S/XUB 7 S/ XUB 7 G SERIES



**XUB6C13G2V**

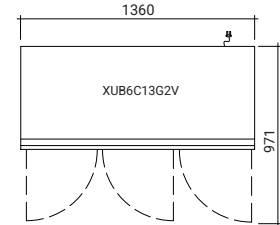
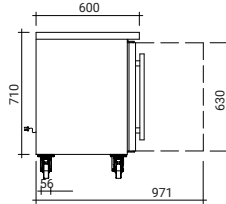
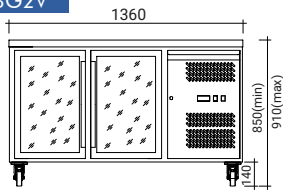

**XUB6C18G3V**

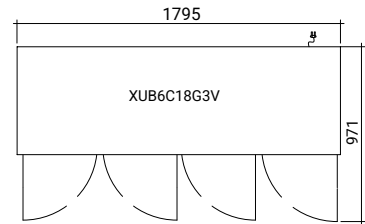
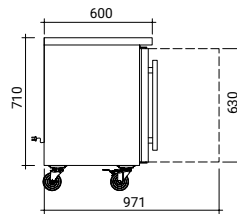
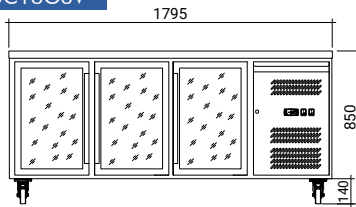

**XUB7C13G2V**

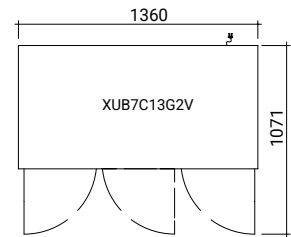
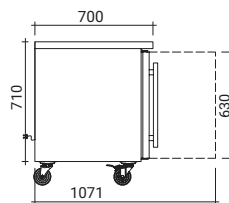
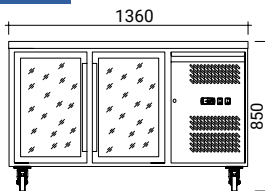

**XUB7C18G3V**

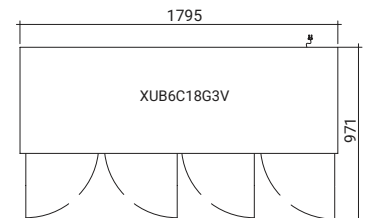
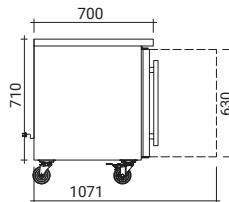
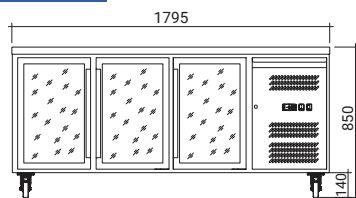

**XUB7C22G4V**

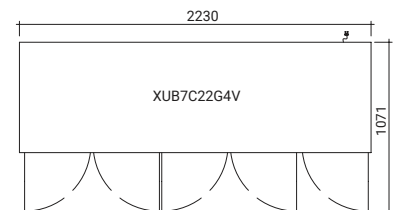
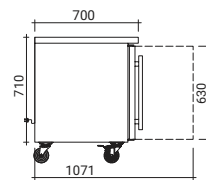
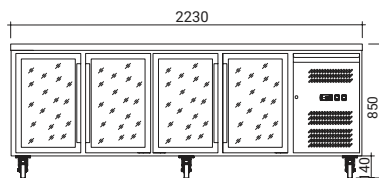

Code	GEMS Star Rating	Gross Capacity (L)	Net Capacity (L)	Doors	Dimensions (WxDxH mm)	Weight (kg)	Temp. Range (°C)	Ambient °C/ RH%	Power (W/A)
<b>600mm Deep with LED lighting inside</b>									
XUB6C13G2V	8	228	214	2	1360x600x850	83	-2 to +8	38/60	215/10
XUB6C18G3V	7	339	254	3	1795x600x850	105	-2 to +8	38/60	230/10
<b>700mm Deep with LED lighting inside</b>									
XUB7C13G2V	4	228	207.5	2	1360x700x850	108	-2 to +8	38/60	215/10
XUB7C18G3V	4	339	311	3	1795x700x850	134	-2 to +8	38/60	230/10
XUB7C22G4V	2	553	415	4	2230x700x850	158	-2 to +8	38/60	345/10

To ensure we continuously offer the best possible products, we reserve the right to modify specifications without any obligation for equipment previously or subsequently sold.



# XUB 6 S/XUB 7 S/ XUB 7 G SERIES



Code	Description	
<b>Optional Splashback Top - 10mm Height</b>		
XUB62-WBB	Splashback top for 2 door 600mm deep under counter unit, suits XUB6C13S2V and XUB6F13S2V	
XUB63-WBB	Splashback top for 3 Door 600mm deep under counter unit, suits XUB6C18S3V and XUB6F18S3V	
XUB64-WBB	Splashback top for 4 Door 600mm deep under counter unit, suits XUB6C22S4V	
XUB72-WBB	Splashback top for 2 door 700mm deep under counter unit, suits XUB7C13S2V, XUB7C13G2V and XUB7F13S2V	
XUB73-WBB	Splashback top for 3 Door 700mm deep under counter unit, suits XUB7C18S3V, XUB7C18G3V and XUB7F18S3V	
XUB74-WBB	Splashback top for 4 Door 700mm deep under counter unit, suits XUB7C22S4V and XUB7C22G4V	
<b>Optional Drawers for XUB7 Series Solid Door Units</b>		
XUB-2DRAWER	1/2 Drawer x 2 with Fulterer heavy duty runner	
XUB-3DRAWER	1/3 Drawer x 3 with Fulterer heavy duty runner	
<b>Additional Shelf Set</b>		
XUB6-SHELFSET	Additional shelf set for 600mm deep under counter units, including one shelving and one pair of runner, suits XUB6C13S2V, XUB6C18S3V, XUB6C22S4V, XUB6F13S2V and XUB6F18S3V	
XUB7-SHELFSET	Additional shelf set for 700mm deep under counter units, including one shelving and one pair of runner, suits XUB7C13S2V, XUB7C13G2V, XUB7F13S2V, XUB7C18S3V, XUB7C18G3V, XUB7F18S3V, XUB7C22S4V, XUB7C22G4V, XGNS900B, XGNS1300B, XGNS1300D, XSS7C13S2V and XSS7C18S3V	
XUB8-SHELFSET	Additional shelf set for 800mm deep under counter units, including one shelving and one pair of runner, suits XSS8C15S2V and XSS8C20S3V	
XGNS-SHELFSET	Additional shelf set for saladettes units, including one shelving and one pair of runner, suits XGNS900E, XGNS1300E, XS900GC, XS903GC and XGNS1300S	
<b>Optional Stainless Steel Runners</b>		
GXE-2-7778	Runner Set for Saladettes, suits XGNS900E, XGNS1300E, XS900GC, XS903GC and XGNS1300S	
GXE-2-211210	Runner Set for 600mm deep under counter units, suits XUB6C13S2V, XUB6C18S3V, XUB6C22S4V, XUB6F13S2V and XUB6F18S3V	
GXE-2-3637	Runner Set for 700mm Deep Under Counter Unit, suits XUB7C13S2V, XUB7C13G2V, XUB7F13S2V, XUB7C18S3V, XUB7C18G3V, XUB7F18S3V, XUB7C22S4V, XUB7C22G4V, XGNS900B, XGNS1300B, XGNS1300D, XSS7C13S2V and XSS7C18S3V	
GXE-2-215216	Runner Set for 800mm deep under counter units, suits XSS8C15S2V and XSS8C20S3V	
<b>Legs</b>		
12533110010	Heavy duty Stainless Steel Leg Adjustable Range 140-200mm (per pc)	



# Undercounter Glass and Solid Door Fridges & Freezers

## XUB 6 S/XUB 7 S/ XUB 7 G SERIES

XUB6C13S2V,XUB6C18S3V,XUB6C22S4V,XUB6F13S2V,XUB6F18S3V,  
XUB7C13S2V,XUB7C18S3V,XUB7C22S4V,XUB7F13S2V,XUB7F18S3V,  
XUB6C13G2V,XUB6C18G3V,XUB7C13G2V,XUB7C18G3V,XUB7C22G4V



**ENERGY RATING**  
THE MORE STARS  
THE MORE SAVINGS

