

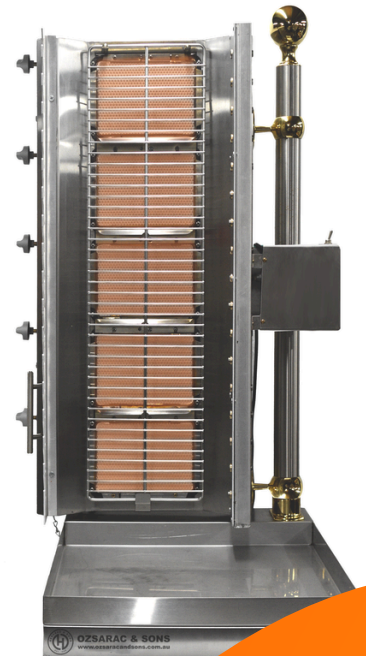

OZSARAC & SONS USER MANUAL

HO4-BMS | HO5-BMS | HO4-BMSB | HO5-BMSB | SK4 | SK5 |

GUIDE ON WARRANTY, INSTALLATION AND OPERATION



**ALL APPLIANCES MANUFACTURED
AND ENGINEERED IN AUSTRALIA**



27 Guernsey st 2161 Guildford NSW

info@ozsaracandsons.com.au

(02) 9632 3119

www.ozsaracandsons.com.au

CONTEXT

Safety instructions	3
Safety instructions contents.....	4
All models	5
Dimensions	5
Basic diagram	6
Construction	6
Installation	7
Data and name plate	7
Typical installation requirements.....	8
Gas and Electrical supply	8
Operating instructions	9
Cleaning	10
Trouble shooting	11
Trouble shooting	12
Appliance commissioning	12
Installation notes	12
Trouble shooting	11
Gas injector conversion or replacement	13
Gas valve removal or replacement	14
Gas injector cleaning process	14
Thermocouple removal or replacement	15
Infrared burner removal or replacement	16
Gear driven motor removal or replacement	17
Wiring diagram	17
Wiring diagram	18
Contact information	19

SAFETY INSTRUCTIONS

WARNING ! : PLEASE ENSURE SAFETY INSTRUCTIONS IS UNDERSTOOD BY ALL PERSONS WHO PROCEED TO INSTALL/USE OUR PRODUCTS

Arabic :

يرجى التأكد من فهم إرشادات السلامة من قبل جميع الأشخاص الذين شرعوا في تثبيت / استخدام منتجاتنا

Chinese :

请确保所有安装/使用我们产品的人员都理解安全说明

Croatian :

MOLIMO VAS PROVJERITE DA RAZUMIJEJU SIGURNOSNE UPUTE SVE OSOBE KOJE NASTAVLJAJU INSTALIRATI/KORISTITI NAŠE PROIZVODE.

Portuguese :

POR FAVOR, CERTIFIQUE-SE DE QUE AS INSTRUÇÕES DE SEGURANÇA ESTÃO COMPREENDIDAS POR TODAS AS PESSOAS QUE PROSSEGUEM A INSTALAR/USAR NOSSOS PRODUTOS.

German :

BITTE STELLEN SIE SICHER, DASS DIE SICHERHEITSHINWEISE VON ALLEN PERSONEN VERSTANDEN WERDEN, DIE UNSERE PRODUKTE INSTALLIEREN/NUTZEN

Italian :

SI PREGA DI ASSICURARE CHE LE ISTRUZIONI DI SICUREZZA SIANO COMPRESSE DA TUTTE LE PERSONE CHE PROCEDONO A INSTALLARE/UTILIZZARE I NOSTRI PRODOTTI

Turkish :

LÜTFEN GÜVENLİK TALİMATLARININ ÜRÜNLERİMİZİ KURMAYA/ KULLANMAYA DEVAM EDEN TÜM KİŞİLER TARAFINDAN ANLADIĞINDAN EMİN OLUN.

Vietnamese :

VUI LÒNG ĐẢM BẢO HƯỚNG DẪN AN TOÀN ĐƯỢC TẤT CẢ CÁC CÁ NHÂN CÀI ĐẶT / SỬ DỤNG SẢN PHẨM CỦA CHÚNG TÔI HIỂU RÕ.

Serbian :

МОЛИМ ВАС ДА СЕ ОБАВЕЗУ ДА СВЕ ОСОБЕ КОЈИ НАСТАВЉАЈУ ИНСТАЛАЦИЈУ/ КОРИШТЕЊЕ НАШИХ ПРОИЗВОДА РАЗУМУЈУ БЕЗБЕДНОСНА УПУТСТВА

Greek :

ΠΑΡΑΚΑΛΩ Βεβαιωθείτε ότι Οι ΟΔΗΓΙΕΣ ΑΣΦΑΛΕΙΑΣ ΕΙΝΑΙ ΚΑΤΑΝΟΗΤΕΣ ΑΠΟ ΟΛΑ ΤΑ ΠΡΟΣΩΠΑ ΠΟΥ ΠΡΟΧΩΡΟΥΝ ΤΗΝ ΕΓΚΑΤΑΣΤΑΣΗ/ΧΡΗΣΗ ΤΩΝ ΠΡΟΪΟΝΤΩΝ ΜΑΣ

Russian :

ПОЖАЛУЙСТА, УБЕДИТЕСЬ, ЧТО ИНСТРУКЦИИ ПО БЕЗОПАСНОСТИ ПОНЯТЫ ВСЕМИ ЛИЦАМИ, КТО ПРИСТУПИТ К УСТАНОВКЕ/ ИСПОЛЬЗОВАНИЮ НАШЕЙ ПРОДУКЦИИ

Malay :

SILA PASTIKAN ARAHAN KESELAMATAN DIFAHAMI OLEH SEMUA ORANG YANG MENERUSKAN MEMASANG/GUNAKAN PRODUK KAMI

SAFETY INSTRUCTIONS CONTEXT

- Allow time to carefully read through and understand all instructions before proceeding to use appliances for all safety as well as making sure the machine is operating properly.
- Never leave appliance unattended while in use.
- Fire extinguisher and blankets must be located within reach of all appliances.
- DO NOT store flammable objects for eg. gas canisters, oven cleaner near appliances.
- DO NOT operate machine with a damages to the electrical unit such as power cords and front switch. Seek Ozsarac services to resolve this issue.
- Avoid liquid getting in contact with any electrical inputs or cords.
- DO NOT use oven cleaner for burner tiles or near them as it will void warranty as well as deteriorate burners.
- Always ensure the gas knobs are facing "off" when machine is not in use.
- Always ensure the power switch is turned off when not in use.
- Do not use machines other than what is intended use is for.
- The machines should NOT be used near children unless there is close supervision.
- Make sure machines are seated on a stable ground or bench.
- DO NOT remove any labels or stickers that are located on the machine.



**ALL PRODUCTS ARE PROUDLY
AUSTRALIAN MADE AND AGA APPROVED**



***ENSURE ALL SAFETY INSTRUCTIONS ARE
UNDERSTOOD BY ALL PERSONS USING THE APPLIANCES.***

OZSARAC **KEBAB COOKERS**

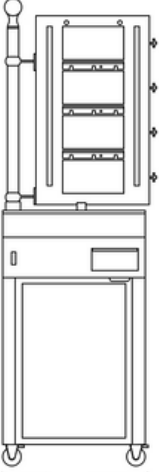
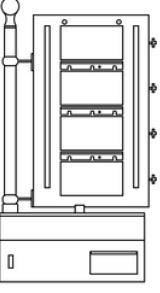
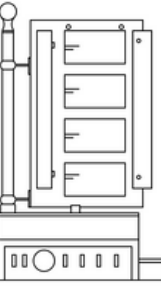
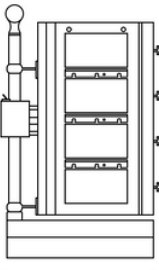
			
HO4BMSB / HO5BMSB	AC054B / AC055B	HO4BMS / HO5BMS	SK4 / SK5
LEFT/RIGHT NATURAL GAS/LPG 5 BURNER/4 BURNER	LEFT/RIGHT NATURAL GAS/LPG 5 BURNER/4 BURNER	LEFT/RIGHT NATURAL GAS/LPG 5 BURNER/4 BURNER	LEFT/RIGHT NATURAL GAS/LPG 5 BURNER/4 BURNER

DIMENSIONS

ALL IN MM

MODEL	W	D	H
HO4BMSB	750	570	1720
HO5BMSB	750	570	1840
HO4BMS	600	570	980
HO5BMS	600	570	1150
SK4	600	570	850
SK5	600	570	1000
AC055B	600	570	980
AC054B	600	570	1150

KEBAB MACHINE SIMPLE DIAGRAM

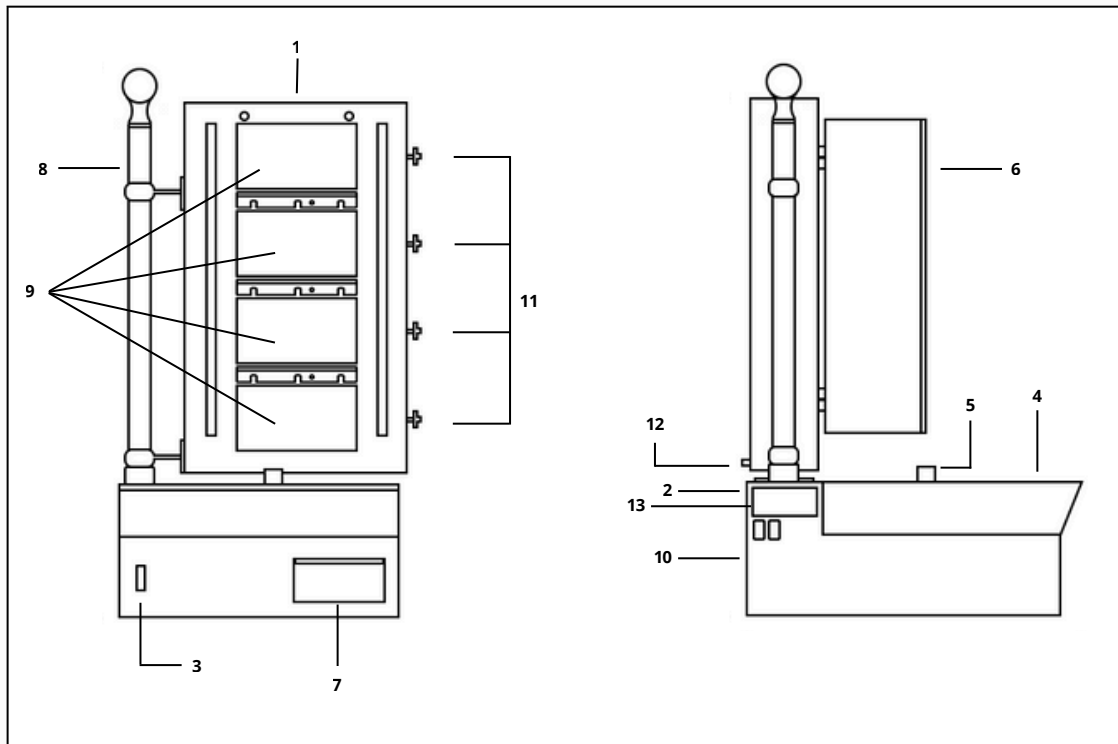

1	Hinged Burner Housing	8	Hinge Post
2	Main Body	9	Radiant Burners
3	Motor Switch	10	Power Outlet
4	Kebab Tray	11	Gas Cocks
5	Shaft (insert shish)	12	Gas inlet
6	Heat Shields	13	Data Plate
7	Oil Tray		

NOTE : Ensure all protective wrapping is removed from the machine prior to initial operation

Construction

Our machines are all complete welded with 1.2mm 304 grade stainless steel with polished joints here in Sydney, Australia

INSTALLATION KEBAB COOKERS

NOTE :

1. Removal of protective wrapping

First the protective film will need to be removed before any appliance is connected including plastic that is on trays, draws and heat shields

2. Authorized person

This appliance is to be installed ONLY by an authorized person in accordance with manufacturers instruction

3. Where to install

This appliance is SUITABLE for installation on boats, still caravans, restaruants and outdoors

ALL INSTALLATIONS MUST COMPLY WITH THE FOLLOWING :

- All relevant gas fitting regulations (Local, State and National)
- All relevant building code (Local, State and National)
- Electrical wiring regulations (Local, State and National)
- Gas installation code AS 5601/AG601
- All other relevant statutory regulations

7.1 Name and data plate with gas and electrical information located on side of appliance

	OZSARAC & SONS		
	MODEL NO. HO4BMS	AGA APPROVAL NO: SC337G	
	SERIAL NO:		
	GAS TYPE:	NATURAL GAS	L.P.G
	GAS CONSUMPTION:	NATURAL GAS: 40MJ/h	L.P.G: 48MJ/h
	KPA:	NATURAL GAS: 1KPA	L.P.G: 2.55KPA
	PHASE: 1	CURRENT: 1.0A	RPM: 2/min

27 GUERNSEY STREET, GUILDFORD NSW 2161
PH: (02) 9632-3119 EMAIL: sales@fastfoodsystems.com.au
Made in Australia

TYPICAL INSTALLATION REQUIREMENTS

- Recommended minimum distance to all combustible materials from back of machine is 150mm
- Recommended minimum distance to all combustible materials from sides of machine is 250mm
- Recommended minimum distance to all combustible materials from front of machine is 600mm
- The rear of the machine should NOT have contact with the back of the wall whilst in operation
- Minimum free ventilation area shall be 300cm²

BENCHTOP (HO4BMS, HO5BMS, SK4, SK5, AC054B, AC055B)

8.1

1. Bench to comply with relevant Australian standards
2. Bench to be secure and lockable if mounted on castors
3. Bench top is to be level
4. If multiple appliances are being installed on the same bench, appliances shall be spaced as such to not cause interference of operation between appliances or their operators

NOTE : When installed using a hose assembly, please attach a restraint chain. The restraint chain length should be 80% of the hose assembly length. The hose assembly should be an AGA approved type B or D with a maximum length of 1.2 metres and to be certified by AS/NZ 1869

FLOOR MODEL (HO4BMSB, HO5BMSB)

8.2

1. Floor is to be level
2. Unit must be locked by its brake swivel castors whilst in operation
3. If multiple appliances are being installed, appliances shall be spaced as such, so it does not cause interference between appliances and their operators

NOTE : All floor models come with a 150mm spacer located on cabinet. The spacer must NOT be removed

GAS AND ELECTRICAL SUPPLY

8.3

Gas supply

1/2" Stainless steel hose with male fitting at rear of unit

Electrical supply

Standard single phase earthed appliance socket rated at 240v, 10 amps

OPERATING INSTRUCTIONS

FOR HO4BMS, HO5BMS, SK4, SK5,
HO4BMSB, HO5BMSB

Normal Operation (cooking)

Starting with the top valve cock

1. Turn gas supply from supply (make sure all gas cocks are turned off first).
2. Start with the top valve cock, ignite a manual lighter and hold it near the burner. After you have the the lighter ignited, firmly press down on the gas knobs and hold it in the on position for about 5 seconds.
3. Once lit, adjust to desired intensity by turn the cock to towards half
4. Repeat steps 1 to 3 for the rest of the burners

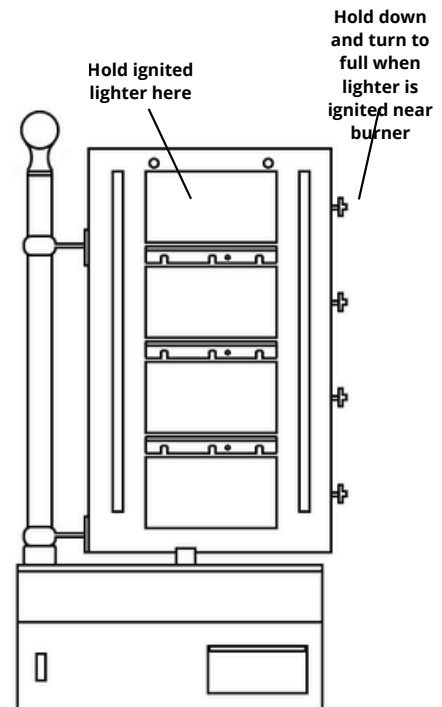

NOTE : DO NOT STORE OR PLACE ANY FLAMMABLE MATERIALS NEAR THIS APPLIANCE

- Each burner is fitted with a flame failure device. if any burner does not ignite or does not continuously burn, it will down the gas projected to the burner

Diagnostics : Call Ozsarac services and inform us or your local plumber

As above, but regards to adjusting individual gas cock

- DO NOT operate machine unless all accessories are fitted as it may cause injury to the operator or to the machine
- Appliance is not to be operated within 3m of flammable materials or liquids
- AEROSOL SPRAYS ARE NOT TO BE USED WITHIN A 3M RADIUS OF THE APPLIANCE WHILST IN USE

It is recommended that this appliance must be serviced and inspected annually at owners cost by and authorised personnel

Items to be checked

- Hose assembly (if fitted) is in good condition
- Burner and flame
- Front grill
- Electrical operation (including rear cord)
- Checking for gas leaks

Cleaning

The appliance has been designed for ease of cleaning

ONLY TO BE CLEANED WHILST NOT IN OPERATIONS

- *DO NOT use harsh solvents/chemicals to clean appliance (incl substances such as oven cleaners, acids etc.)*
- *Hot soapy water will clean all stainless steel surfaces*
- *Avoid liquid contact with the radiant tiles in each burners as this can cause permanent damage to the tiles and will not cover warranty.*
- *Consider avoiding saturation of the electrical system*
- *DO NOT clean machine with flammable materials/liquids, as residue may ignite when machine is in operation*

TO THE INSTALLER

On completion of the installation, light all burners to ensure that they are operating correctly and inform customer on how to operate this appliance. If this appliance appears to be operating incorrectly, eg. sooting or emitting unusual odours, please turn the appliance off as well as turning the main gas line off and contact Ozsarac and Sons PTY LTD.

TROUBLE SHOOTING

PROBLEM	CHECK	ACTION 1	ACTION 2
Nothing happens when power turns 'on'	Appliance power cord	Replace if needed	
	Main power supply	Reset main switch	Call electrician
Burners will not light	Gas cock	Open gas cock and attempt to relight	Check pressure of regulator
Some burners light whilst others wont	Main supply	Turn on main supply	Call service provider
	Burner jets are not blocked	Remove gas jets from manifold and attempt to unblocked using air pressure	Replace gas jets
	Gas pressure at regulator	Adjust regulator to correct pressure	Call service technician or plumber
Motor running but rotisserie is not rotating	Check drive train	Re-instate chain onto motor sprocket	
Appliance will not work properly			Contact manufacturer

APPLIANCE COMMISSIONING

- *Appliance commissioning shall be carried out as per AS5601 - 2004 section 9 by a suitable qualified tradesman or clause 2.6.8 of AS/NZS 5601-2013*

To Be Considered During Commissioning

1. *AS1668 parts 1 and 2 commercial kitchen exhaust hoods*
2. *AS5601 gas installations*
3. *All statutory requirements of local authorities*
4. *Gas fitting regulations 153-155-156*

TROUBLE SHOOTING

NOTES :

- Ensure electricity supply is isolated prior to any action being taken
- Ensure gas supply is isolated prior to any action being taken
- All appliance repairs should only be carried out by an authorized person

INSTALLATION NOTES

Gas supply piping to the appliance(s) must be designed in accordance with the A.G.A Installation code for piping sizing

- Connection to the appliance(s) must be in accordance with the AUSTRALIAN STANDARD GAS INSTALLATION CODE AS 5061
- Isolation valve to be fitted to gas inlet
- Recommended connector between mains supply and appliance is : *1/2" x 300/600 Aqua neck, S/S flexible connector . Ref, 4007 or AGA approved equivalent-class B assembly complying with AS 1869*
- The regulator supplied with the unit must be installed in accordance with gas installation code
- A chain is the fitting between the appliance adjacent permanent structural fixture in such so it does not allow the gas supply hose to be stressed in any direction
- Electricity supply is via a standard 240v 10amp appliance cord
- Appliance shall only be tested with all accessories fitted
- Ensure all accessories are fitted correctly

LPG TO NATURAL GAS CONVERSION

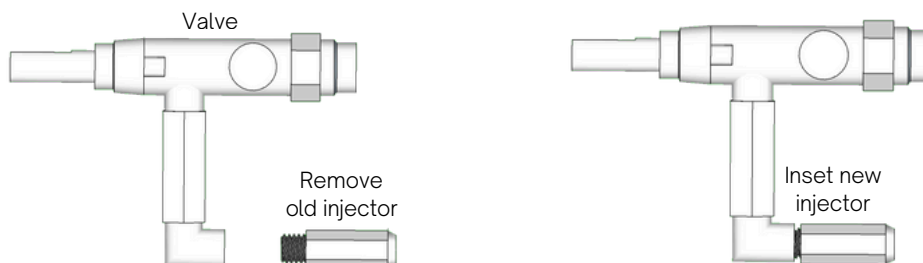

NOTE :

Conversion must be carried out by an authorised gas installation person (plumber)

INSTRUCTIONS :

1. Ensure gas supply is turned off at mains
2. Disconnect connection at rear of machine
3. Ensure all gas has been purged from the machine
4. Remove the back cover of the machine
5. Remove back cover of machine
6. Loosen the injectors with a 11mm spanner
7. Use two index fingers to remove the injector. (make sure the burners are cold to prevent injury).
8. Apply thread tape to the thread of the new injector
9. Insert new gas injector to suit fuel supply:
 - Natural gas: 1.50mm dia hole size**
 - LPG: 0.95mm dia hole size**
10. Tighten injectors with a 11mm spanner
11. Place back the burner covers
12. Place back back cover
13. Reconnect gas supply to rear of machine outlet
14. Ensure the approved regulator is installed for the fuel supply to be used
15. Ensure the approved regulator is set to the correct pressure
 - Natural gas: 1.00kpa**
 - LPG: 2.65kpa**
16. Turn on mains supply back on
17. Test for any gas leaks between injector and gas valve
18. Mark appliances with gas type and data plate information

NOTE:

Use only parts supplied by Ozsarac And Sons PTY LTD.

LPG TO NATURAL GAS CONVERSION

Tools will be needed

- Phillip screw driver
- 10mm spanner
- 14mm spanner

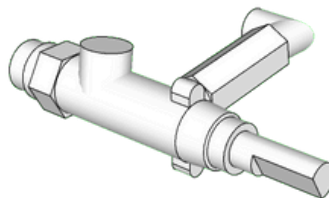

NOTE:

BEFORE ANY MAINTANCE PLEASE DISCONNECT AND TURN OFF GAS MAINS

Instructions

1. On the rear top section of the unit, remove the 4 screws holding the back cover in place with the philips screw driver
2. Once rear cover is removed, there are individual galvanise covers on each burner that are held in place by 2 nuts and screws, these need to be removed
3. Once burner covers are removed, there is two 10mm screws on the side of the top where the gas knobs are that hold the gas manifold. These need to be removed.
4. Once the screws are removed, slide the manifold out
5. Put the manifold on a vice grip and use your 14mm spanner on one of the gas valves that need to be removed and turned the whole gas valve anti clockwise.
6. Remove gas valve and insert your new gas valve and repeat steps 5,4,3,2,1 in order.

CLEANING GAS INJECTOR

Tools will be needed

- Phillip screw driver
- 11mm spanner

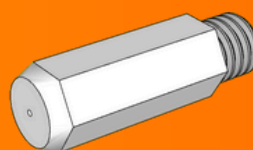

NOTE:

BEFORE ANY MAINTANCE PLEASE DISCONNECT AND TURN OFF GAS MAINS

Instructions

1. On the rear top section of the unit, remove the 4 screws holding the back cover in place with the philips screw driver.
2. Once the back cover is removed, there are individual galvanise covers on each burner that are held in place by 2 nuts and screws. These need to be removed
3. Using 11mm spanner, remove the injectors
4. Using a ping like object, poke the existing hole on the tip of the injector and remove any dust or debris blocking its flow path
5. Using steps backwards, repeat steps.

REMOVAL OF THERMOCOUPLE

Tools will be needed

- 8mm spanner
- Philip head screw driver
- Long nose pliers

NOTE:

BEFORE ANY MAINTANCE PLEASE DISCONNECT AND TURN OFF GAS MAINS

Instructions

1. Ensure that the as is turned off by the main valve
2. On the rear top section of the unit, remove the 4 screws holding the back cover in place with the philips screw driver
3. Once the cover is removed, locate the faulty thermocouple and undo the nut driving into the top of the gas valve with a 8mm spanner rotating anti clockwise
4. Once it has been removed from the valve go ahead and detach it from the burner by hold the nut from the back of the machine with a long nose plier and rotating the screw at the front of the burner anti clockwise with a philips screw driver
5. Once undone, you can now remove thermocouple and repeat steps 4,3,2,1 in order to install new thermocouple

REMOVAL OF INFRARED BURNER

Tools will be needed

- Cordless drill driver
- 4mm drill bit
- 4 x 4mm pop rivet
- Pop rivet gun
- 8mm spanner
- Philip screw driver

NOTE:

BEFORE ANY MAINTANCE PLEASE DISCONNECT AND TURN OFF GAS MAINS

Instructions

1. You will need to take off the four(4) philip head screws located on the rear top part of the unit that holds the back cover in place
2. Once you have removed the back cover, you will need to take the screw and nut located on the burner that holds the thermocouple in place (only that screw and nut must be removed) using a long nose plier and a screw driver, this can be achieved
3. Once thermocouple is removed for burner housing, you will need to go to the front of the machine and drill out the 4 pop rivets that hold the desired burner in place
4. You will now be able to remove the burner from the unit
5. Once removed, place new burner in the same housing making sure the gas inlet of burner is facing towards the gas injectors
6. Once placed in housing, apply 4 pop rivets to each corner of the burner and use the pop rivet gun to secure into place
7. Place back back cover and connect main gas hose

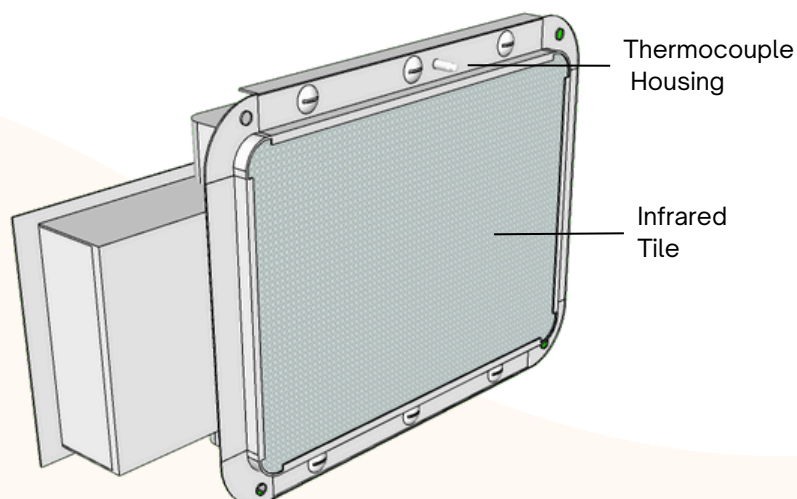

MODEL USES

- HO4BMS
- HO5BMS
- SK4
- SK5
- HO4BMSB
- HO5BMSB

REMOVAL OF MOTOR

Tools will be needed

- Male and female spade terminals - 1x male, 1x female
- Phillip screw driver
- 10mm spanner
- Pliers

NOTE:

BEFORE ANY MAINTANCE PLEASE DISCONNECT AND TURN ELECTRICAL CONNECTION

Instructions

1. Make sure electrical cable is removed from the socket
2. Remove the 6 screws located at the rear bottom base of the unit
3. Remove the 3 female electrical terminals from the socket
4. Undo the 2 cables that connect from front switch to motor
5. Use a 10mm spanner to remove the 4 hex head screws located on the motor bracket
6. Once removed, using pliers undo the chain connected to the sprocket of the motor
7. You can now remove the motor and insert new motor into housing
8. Once new motor is inserted, use diagram and 2x terminals to reconnect motor to front switch
9. Once connected make sure no copper cables are exposed anywhere on the machine and connect the 3 terminals originally removed from back socket, back onto the socket via diagram
10. Place back cover on the rear and re-screw the 6 screws onto the back cover with a philips screw driver

WIRING DIAGRAM

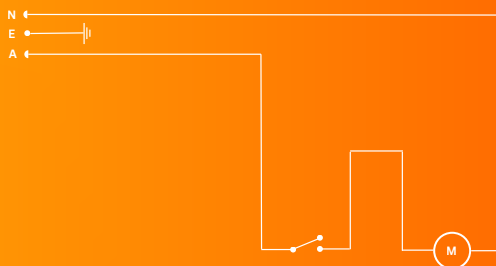



27 Guernsey st 2161 Guildford NSW

info@ozsaracandsons.com.au

[\(02\) 9632 3119](tel:(02)96323119)

www.ozsaracandsons.com.au